

**ASSEMBLY & INSTALLATION NOTES**

**JUBU upgrade belt drive pulley kit (JU00004PRD)**

for 2GR-FE 7PK & 8PK

**Please follow the instructions in this manual for a proper assembly & installation of the JUBU upgrade belt drive pulley kit 7PK & 8PK for 2GR-FE.**

Please find in this document:

- 1. PART LIST**
- 2. ASSEMBLY & INSTALLATION NOTES**

**1. PART LIST for product JU00004PRD**

#	ITEM	ART-NO.	UNITS
1	Upgrade pulley bearing	JU00055ART	2
2	Upgrade pulley sleeve 7PK & 8PK	JPP620118	2
3	Upgrade pulley spacer 7PK & 8PK	JPP620144	1

Note: The Upgrade bearings (1) and the Upgrade pulley sleeves (2) are pre-assembled according to Fig 2 and Fig 3.



Fig 1: Scope of delivery

### (I) Engine mounted pulley

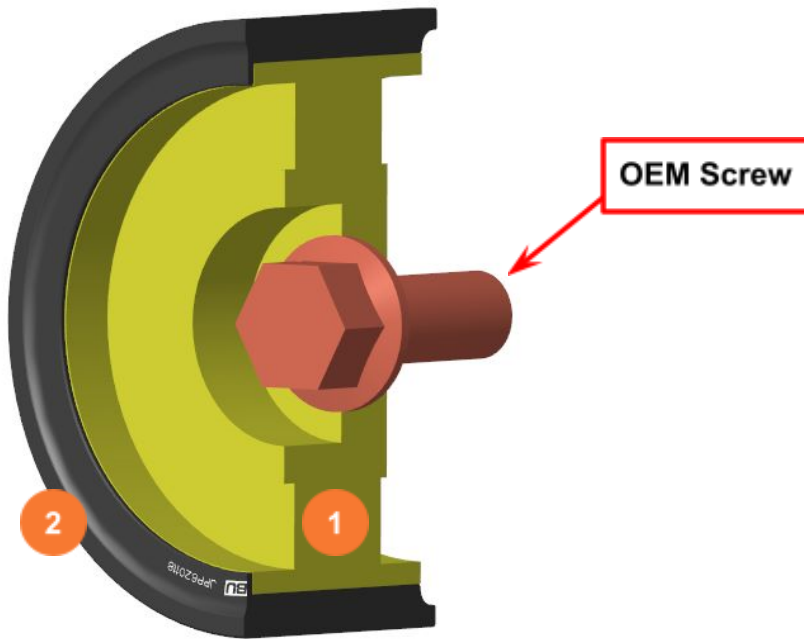

*Fig 2: Engine mounted pulley*

### (II) Tensioner pulley

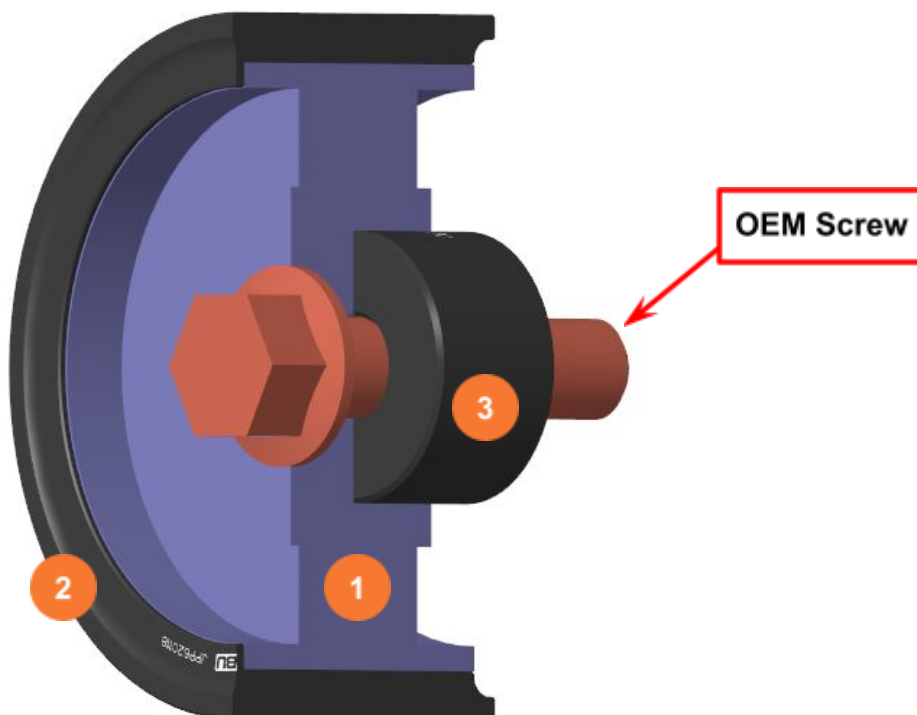

*Fig 3: Tensioner pulley*

## 2. ASSEMBLY & INSTALLATION NOTES

1. Disassemble the OEM engine mounted pulley and belt tensioner pulley.
2. Screw the pre-assembled engine-mounted pulley (I) onto the engine as shown in Fig. 4 using the OEM screws, tightening them with OEM torque (43Nm) and using **LOCTITE 243** locking lacquer.
3. Screw the pre-assembled belt tensioner pulley (II) onto the belt tensioner as shown in Fig. 4 using the OEM screws, tightening them with OEM torque (43Nm) and using **LOCTITE 243**locking lacquer.
4. **!** **NOTE:** These Pulleys can be used for 7PK and 8PK belt systems, the belt might not run in the center of the pulley.

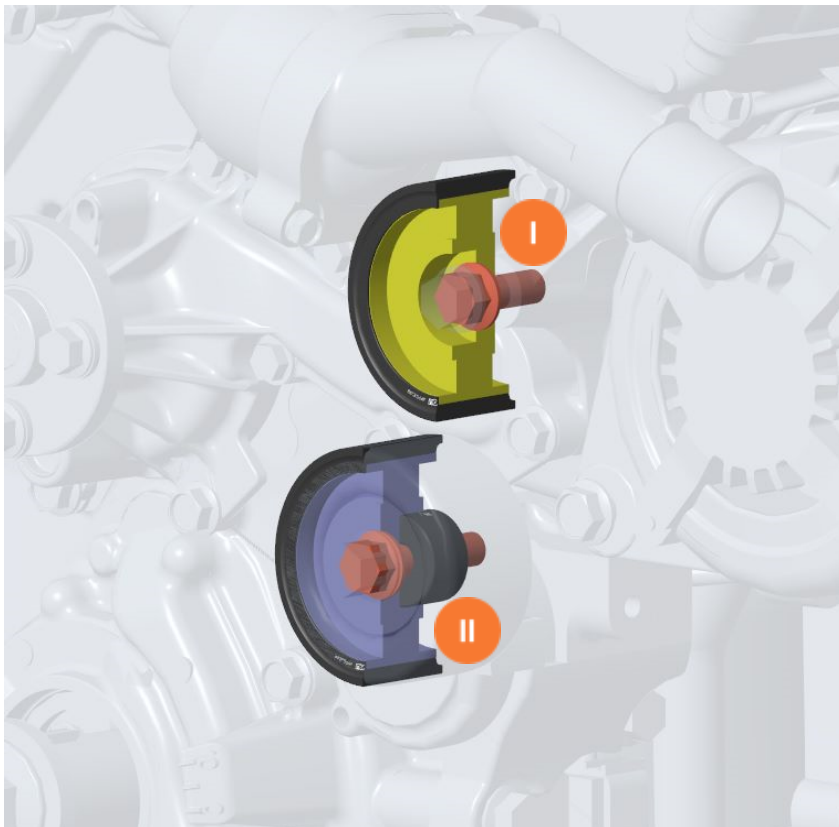

Fig 3: Correct assembly of the upgrade belt drive pulleys.

\*\*\*\*\*

If you have any questions or need additional information, please contact us by email:

[info@jubu-performance.com](mailto:info@jubu-performance.com)

**JUBU Performance GmbH**

Saxenegg 3a, 4323 Münzbach, AUSTRIA